



A higher level of performance

Data Sheet

SULTAN

Acoustic Wave Series

- Level, Flow, Positioning, Collision Protection -

Principle of Operations

The SULTAN 234 emits a high powered **acoustic wave** transmit pulse which is reflected from the surface of the material being measured. The reflected signal is processed using specially developed software to enhance the correct signal and reject false or spurious echoes.

The transmission of high powered acoustic waves ensures minimal losses through the environment where the sensor is located. Due to the high powered emitted pulse, any losses have far less effect than would be experienced by traditional ultrasonic devices. More energy is transmitted hence more energy is returned. Advanced receiver circuitry is designed to identify and monitor low level return signals even when noise levels are high. The measured signal is temperature compensated to provide maximum accuracy to the outputs and display.

Primary Areas of Applications

• Waste water/water:

River level, wet wells, inlet screens, tanks, sumps, pump stations, water towers, dams, basin levels, chemical storage, etc.

• Mining:

Crushers, surge bins, ore passes, conveyor profile, blocked chute, stockpile, stackers, reclaimers, storage silos etc.

• **Power Stations:**Boiler bunkers, raw coal bunkers, ash pits, fly ash silos, etc.

• Others:

Food, Cement, Plastics, Grain, Chemicals, Paper, Irrigation, Quarries

Function

The Sultan 234 is a non intrusive acoustic wave transmitter with flexibility, used for measuring level of liquids, slurries and solids.

Universal Supply

- 2 Wire Loop Powered
- 3 Wire DC
- 4 Wire AC/DC

Certifications

ATEX, SAA/IECEX, CE, CSA (FM pending)



Features:

- Non contact measurement
- High Power even with two wire loop supply
- Low cost per point
- Wide range of communications: DeviceNet, GosHawk, HART, Modbus, Profibus DP, Foundation Fieldbus & Profibus PA
- Pump Control x5 pumps
- Auto compensation for dust, steam and losses
- Protection class IP67, NEMA 4x (IP68 Transducer)
- Programmable fail safe mode
- High temp applications on request
- GSM/CMDA remote setup options/config
- Differential and average level control (2 transducers)

Typical Applications

Conical Shape Vessels

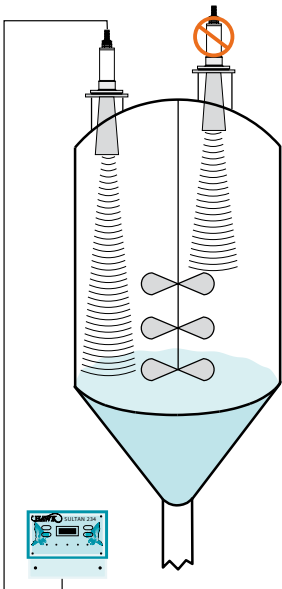

Horizontal Cylindrical/Ball Tanks

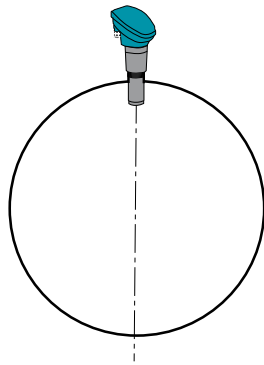

Sultan Acoustic Wave Transmitter

Stockpiles, Stackers, Reclaimers

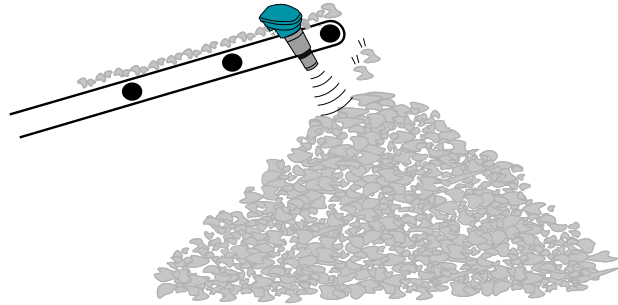

Solids Vessels

High/Low/Continuous level
(Granular/Powder)

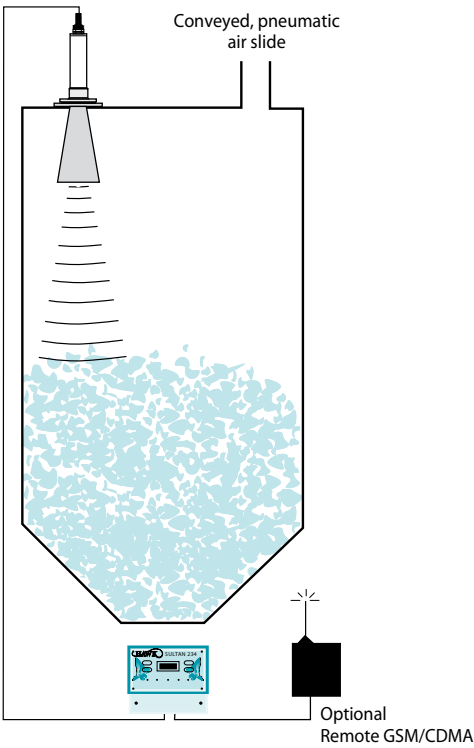

Storage Tanks

High/Low/Continuous level
(Liquid/Chemical)

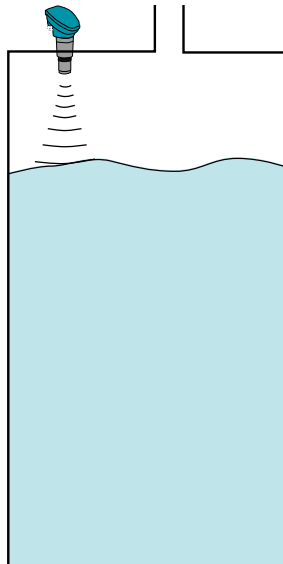

Sewage Wet Well

High/Low/Continuous level
Up to 5 Pumps

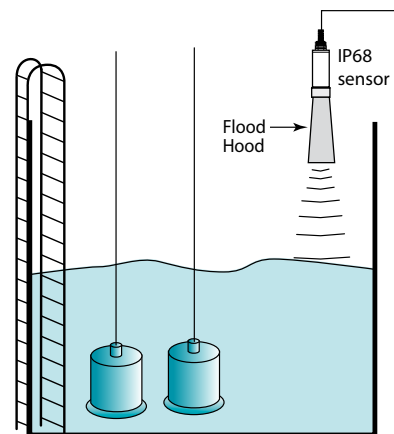

Remote Amplifier



or



Panel Mount

INTEGRAL UNITS

Standard Flanged Type

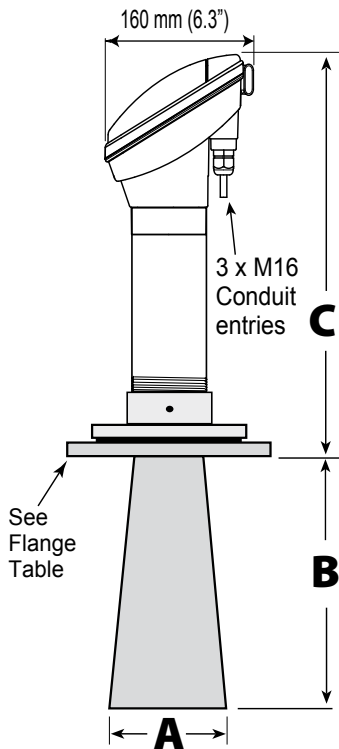

Compact Type (2" BSP/NPT)

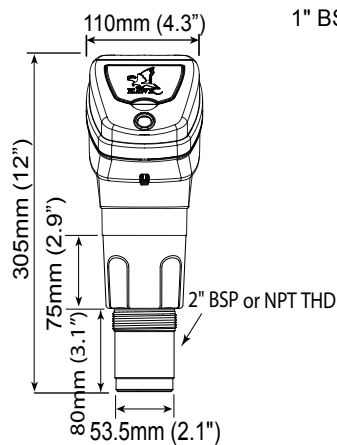

SMART UNITS AND REMOTE TRANSDUCERS

Standard Flanged Type

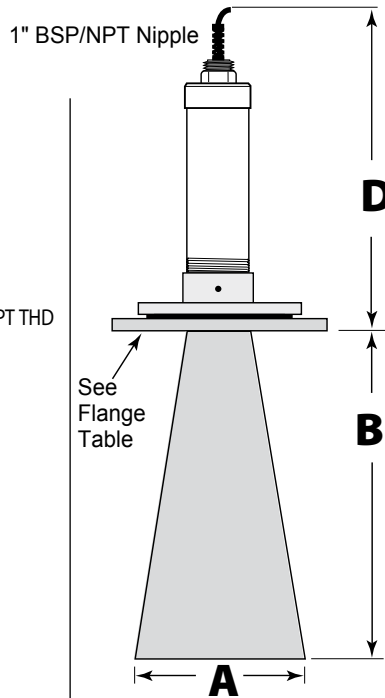

Compact Type (2" BSP/NPT)

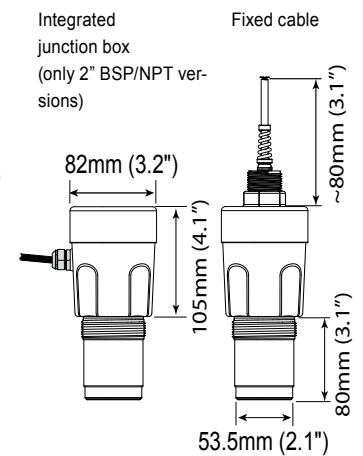

| Dimensions Table | | | | | | | | | |
|------------------|-----------------|------|-----|-----|------|-----|------|-----|------|
| Sensor Frequency | Selected Flange | A | | B | | C | | D | |
| | | mm | in | mm | in | mm | in | mm | in |
| 5 kHz | 10" | 236 | 9.2 | 455 | 17.9 | 840 | 33.1 | 750 | 29.5 |
| 10 kHz | 10" *8" | 236 | 9.2 | 415 | 16.3 | 540 | 21.3 | 450 | 17.7 |
| | | 195 | 7.6 | 280 | 11.1 | 540 | 21.3 | 450 | 17.7 |
| 15 kHz | 10" *8" | 236 | 9.2 | 455 | 17.9 | 440 | 17.3 | 350 | 13.8 |
| | | 195 | 7.6 | 280 | 11.0 | 440 | 17.3 | 350 | 13.8 |
| 20 kHz | 4"/*6" | 98.5 | 3.9 | 280 | 11.0 | 390 | 15.4 | 300 | 11.8 |
| 30 kHz | 4"/*6" | 98.5 | 3.9 | 280 | 11.0 | 350 | 3.8 | 260 | 10.2 |

*6" and 8" are non standard. Please contact factory before selecting.

All horns must protrude into the main volume of the vessel by at least 50 mm (2 inches) past the lower end of the mounting nozzle.

FLANGE

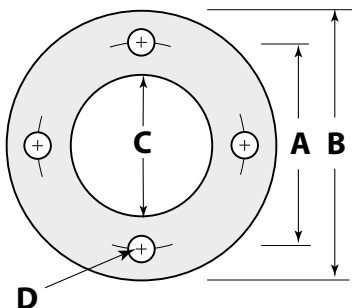

FLANGE TYPE:
 A = ANSI Flange
 J = JIS Flange
 D = DIN Flange

STANDARD ANSI/DIN/JIS FLANGE DIMENSIONS

| SIZE | FLANGE TYPE | A (PCD) | | B (OD) | | C (ID) | | D (Hole) | |
|------|-------------|---------|------|--------|------|--------|-----|----------|------|
| | | mm | in. | mm | in. | mm | in. | mm | in. |
| 4" | FA4 | 190.5 | 7.5 | 228 | 9.0 | 100 | 4 | 19 | 0.75 |
| | FD4 | 180 | 7.0 | 220 | 8.7 | 100 | 4 | 18 | 0.7 |
| | FJ4 | 175 | 6.9 | 210 | 8.4 | 100 | 4 | 15 | 0.6 |
| 10" | FA10 | 362 | 14.3 | 406 | 16.0 | 250 | 10 | 25 | 1.0 |
| | FD10 | 350 | 13.8 | 395 | 15.6 | 250 | 10 | 22 | 0.85 |
| | FJ10 | 355 | 14.0 | 400 | 15.7 | 250 | 10 | 23 | 0.9 |

NON STANDARD ANSI/DIN/JIS FLANGE DIMENSIONS

| | | | | | | | | | |
|----|-----|-------|------|-------|------|-----|---|----|------|
| 6" | FA6 | 241 | 9.5 | 279.5 | 11.0 | 150 | 6 | 22 | 0.85 |
| | FD6 | 240 | 9.4 | 285 | 11.2 | 150 | 6 | 22 | 0.85 |
| | FJ6 | 240 | 9.4 | 280 | 11.0 | 150 | 6 | 19 | 0.75 |
| 8" | FA8 | 298.5 | 11.8 | 343 | 13.5 | 200 | 8 | 22 | 0.85 |
| | FD8 | 295 | 11.6 | 340 | 13.4 | 200 | 8 | 22 | 0.85 |
| | FJ8 | 290 | 11.4 | 330 | 13.0 | 200 | 8 | 19 | 0.75 |

Note: Other flange sizes available upon request.

Dimensions

REMOTE AMPLIFIERS

Field Mount

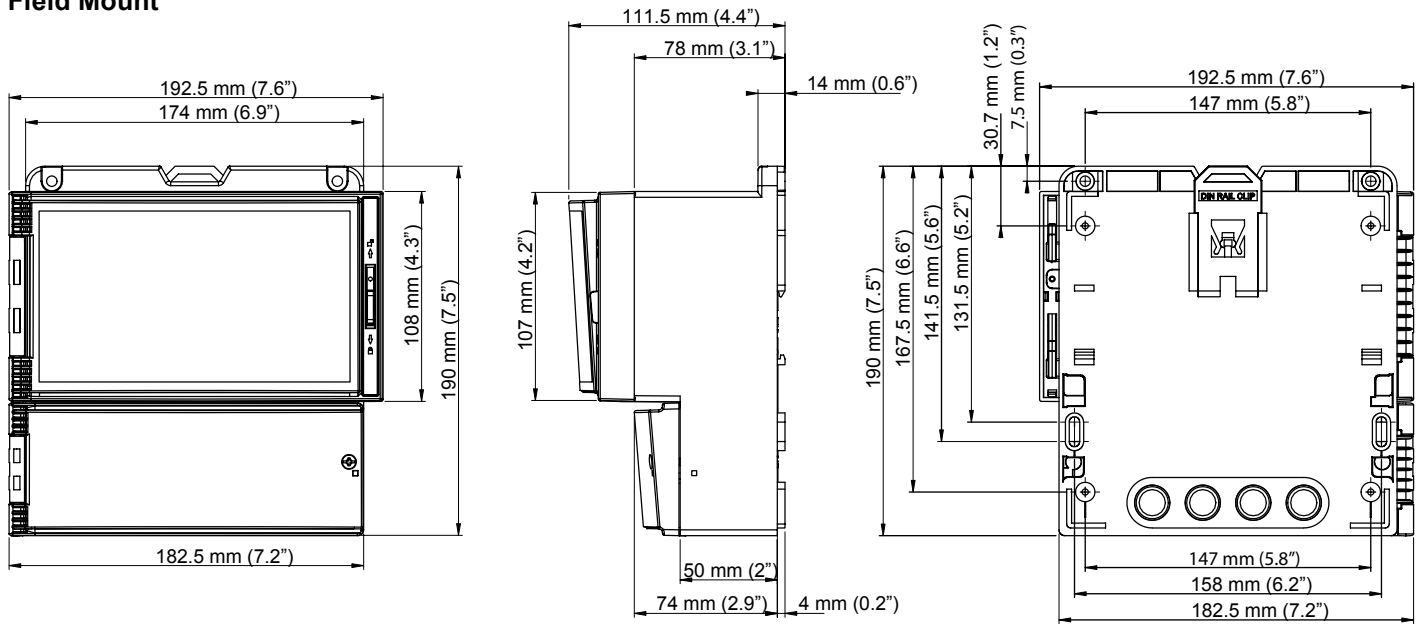

Panel Mount - cut out size 90x90mm (3.54x3.54")

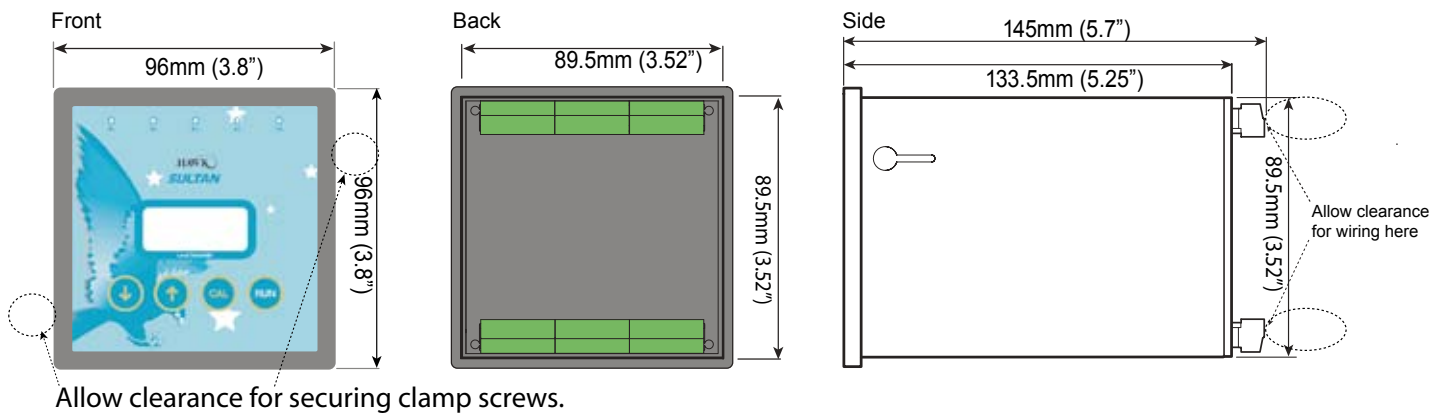

Communication Network Overview

MULTIDROP CONNECTION

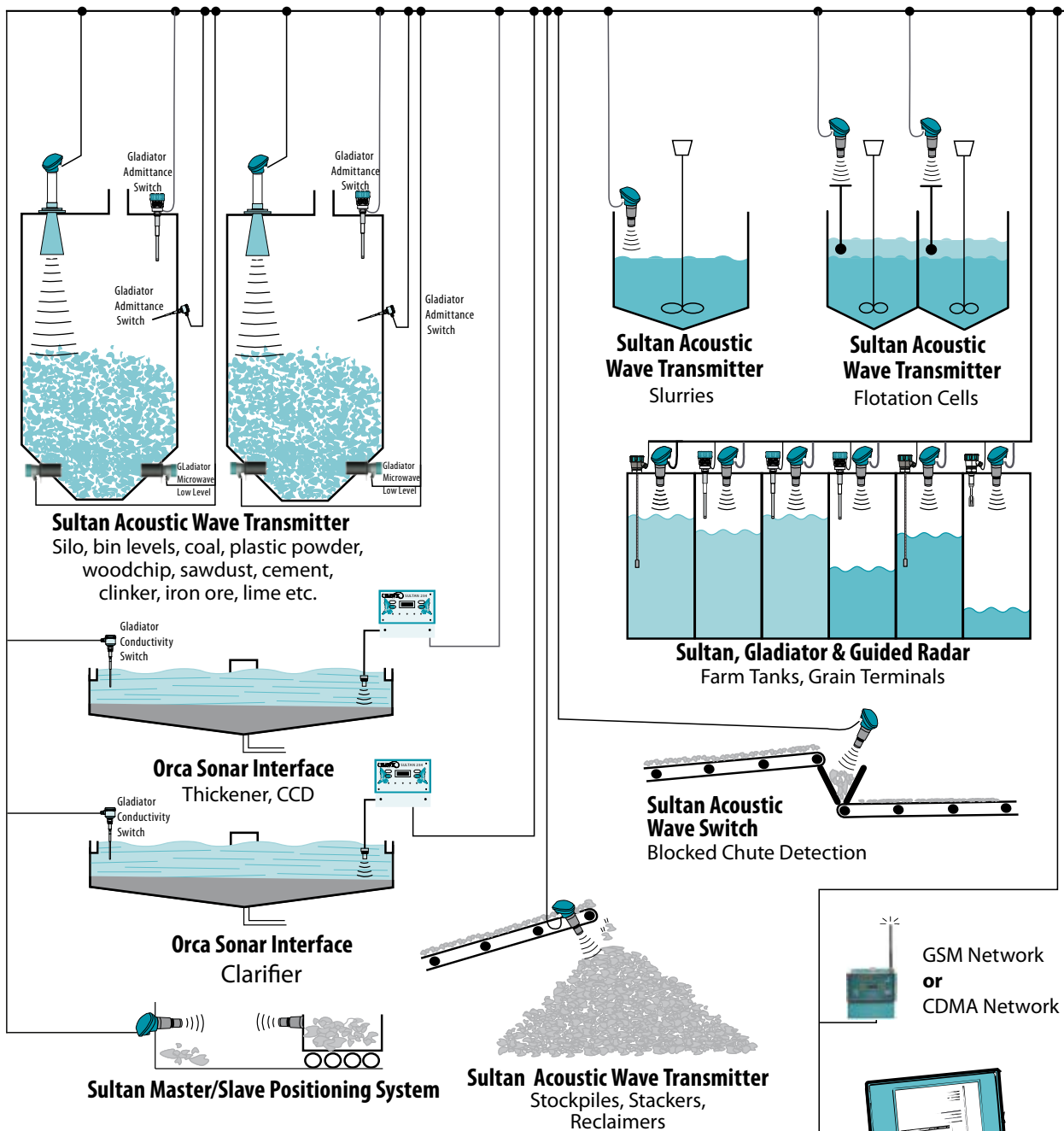

GSM or CDMA Network

- Typically up to 31 transmitters or switches per string.
- Maximum 250 transmitters or switches.
- Using GSM/CDMA network, transmitters and switches can be monitored, calibrated remotely.
- Alarm status, diagnostics can be monitored.
- Support from factory engineering for customer application problems.

Laptop or PC Communications
or PLC / DCS with
MODBUS RTU Port
GosHawk Software for
inventory monitoring on PC

(Limited Modbus query rate for Switches only)

Wiring Diagrams

Sultan 234 Models AWI234 Series Transmitter Integral Version (2 Relays)

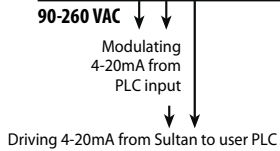
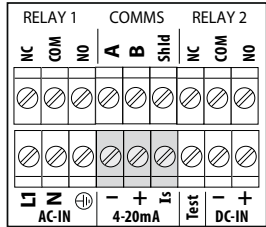

AWR234S Series Transmitter Remote Field Mount (5 Relays)

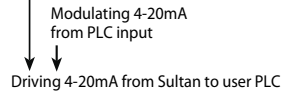
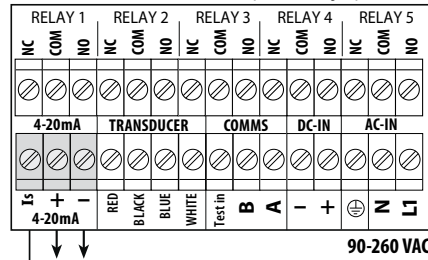

AWR234P Series Transmitter Remote Panel Mount (5 Relays)

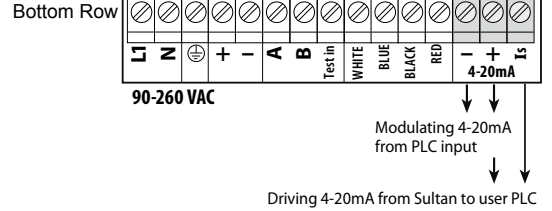
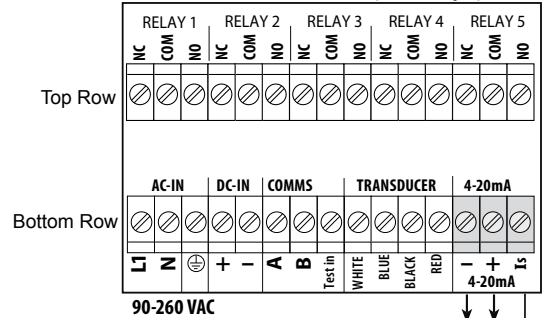

4-20mA SOURCING Type Output

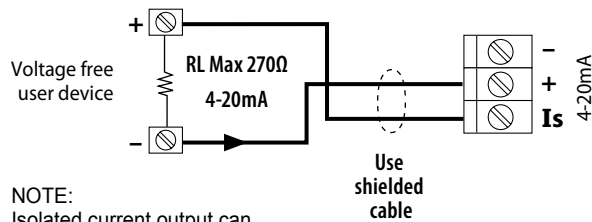

NOTE:
Isolated current output can be made common with +DC or GND if required. (e.g. RL – connected to GND)

Sultan output is sourcing current and provides voltage to drive a passive load, PLC input, indicator or other user device

4-20mA SINKING Type Output (also 2 wire loop powered)

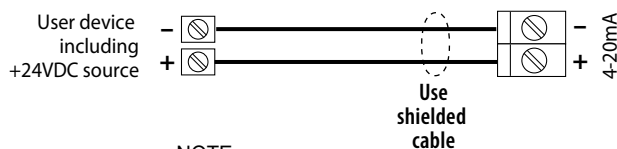

NOTE:
RL Max = 750Ω
if user DC Supply 24V

Sultan output is sinking current. Voltage to drive current loop must be provided by PLC, indicator, other user device or external DC supply.

For further connection options see Sultan manual

Part Numbering

SULTAN AW REMOTE ELECTRONICS

- AWR2** Remote 2 Wire Housing/Facia Display Connection Board/Process Module, No relays
- AWR234** Remote 2/3/4 Wire Housing/Facia Display Connection Board/Process Module, 5 relays
- AWFR234** Remote 2/3/4 Wire Housing/Facia Display Connection Board/Process Module, 5 relays for Flow

HOUSING

- S Standard polycarbonate electronics housing
- P Panel Mount Housing (not available for Flow)

POWER SUPPLY

- B 24 VDC standard
- C 48 VDC for 2/3/4 units only
- U Universal DC or AC power supply (12-30 VDC or 90-265 VAC input) for 234 units only

ADDITIONAL COMMUNICATIONS

- S Switch only. 5 relays for AWR234 only
- X 4-20mA analogue output module, includes Modbus comms
- H HART 2 wire only
- I HART Isolated 4 wire 2/3/4 only
- W Modbus Comms only (not available for 2 wire Sultan)
- P Profibus DP*
- A Profibus PA*
- F Foundation Fieldbus*
- E Ethernet*
- D DeviceNet*
- Z Special Request

INTERNAL HAWKLINK MODEM (available with ATEX 0/20 approval)

- X Not required
- G2 GSM Frequency 800/1900 MHz/19200 Baud for USA,Canada,Chile,Argentina for Sultan 234 only
- G4 GSM Frequency 900/1800 MHz/19200 Baud for Australia,Europe,Brazil for Sultan 234 only

APPROVAL STANDARD

- X Not required
- A0 ATEX 0 only for AWR2 (Areas II I GD IP67 Eexia II A T4) / IECEx Ex ia IIA T4 (Tamb -20C to +70C)
- A22 ATEX Dust (Grp II Cat 3 D T85C IP67)
- GP CSA Equip Class 2, Pollution Deg.2, Measurement II (Ordinary locations)
- RN CSA Class I, Div. 1/2, Group D; Zone 0; AEx/Ex ia IIA; T4
- KN CSA Class II, Div. 2 Grp F&G; Class III

POSITION UNIT / CRANE MASTER SOFTWARE OPTIONS

- PS Position Slave
- CM Crane Master
- X Not required

| | | | | | | |
|------|---|---|---|---|---|---|
| AWR2 | S | B | X | X | X | X |
|------|---|---|---|---|---|---|

*Cannot be used with internal HawkLink, only with remote HawkLink.

SULTAN AW REMOTE TRANSDUCER

AWRT Acoustic Wave Remote Transducer

TRANSDUCER FREQUENCY

- 50 50kHz for applications 0-5m, available 2" only
- 40 40kHz for applications 0-7m, available 2" only
- 30 30kHz for applications up to 11m for 2" and 15m for 3" (4" cone is recommended for 3" units)
- 20 20kHz for applications up to 20m, available in 3" only (4" cone is recommended)
- 15 15kHz for applications up to 30m, available in 3" only (10" cone is recommended)
- 10 10kHz for applications up to 40m, available in 3.5" only (10" cone is recommended)
- 09 09kHz for high power extended range applications up to 170m (10" cone is recommended)
- 05 05kHz for applications up to 60m maximum, available in 3.5" only (10" cone is recommended)
- 04 04kHz for high power extended range applications up to 170m (10" cone is recommended)

PROCESS TEMPERATURE - Facing material selection

- S Standard Temperature Dry atmosphere only, (polyofin face) for 4, 5, 9 10 and 15kHz only
- T Standard Temperature Wet or dry atmosphere (teflon face)
- Y High Temperature (Wet or dry atmosphere,150C, Titanium face) 10kHz only
- Z Special Request

TRANSDUCER HOUSING MATERIAL

- 4 Polypropylene
- 6 Tefzel for 2" (standard). For 3" Teflon please contact us

THREAD STANDARDS (cone mounting thread does not need to be specified)

- X Not Required (see flange & cone selection)
- TB BSP (Must be used for thread sizes 30 or 50. For back cap mounting of flange.)
- TN NPT

THREAD SIZES

- X Not Required
- 20 2" thread for 50,40,30 kHz in Tefzel housing only
- 30 3" thread on the back cap for 30, 20, 15 kHz only (For back cap mounting of flange, use TB option)
- 50 3.5" thread on the back cap for 10 and 5 kHz only (For back cap mounting of flange, use TB option)

APPROVAL STANDARD

- X Not required
- A0 ATEX 0 only for AWR2 (Areas II I GD IP67 Eexia II A T4) / IECEx Ex iaIIA T4 (Tamb -20C to +70C)
- A1 ATEX Encapsulated (Areas II 2 GDEExm II IP68)
- A20 ATEX Dust (Areas II 1 D T85C IP67)
- A21 ATEX Dust (Areas II 2 D T85C IP67)
- A22 ATEX Dust (Areas II 3 D T85C IP67)
- GP CSA Equip Class 2, Pollution Deg.2, Meas. Cat.II (Ordinary locations)
- RN CSA Class I, Div. 1/2, Group D; Zone 0; AEx/Ex ia IIA; T4
- QN CSA Class II, Div. 1 Grp E,F&G; Ex mb II; T5(T100),T6(T85)
- KN CSA Class II, Div. 2 Grp F&G; Class III

CONNECTION

- S Screwtop unit with integral junction box (available only for 2" units)
- C IP68 Sealed unit with 6 metre cable

Cable Length

- 6 6m cable standard
- 15 15m cable
- 30 30m cable
- 50 50m cable
- X Not Required

MOUNTING ACCESSORIES

- X Not Required
- CS Cable Suspension for remote 50/40/30/20kHz

POSITION UNIT / CRANE MASTER SOFTWARE OPTIONS

- PS Position Slave
- FP Fast Pulsing (not available for cranemaster/position)
- F Flow including multifit shading flange and fast temp compensation
- X Not required

| | | | | | | | | | | |
|------|----|---|---|---|---|---|---|---|---|---|
| AWRT | 50 | S | 4 | X | X | X | S | X | X | X |
|------|----|---|---|---|---|---|---|---|---|---|

Part Numbering

SULTAN AW INTEGRAL

AWI2 Integral 2 Wire, Housing/Facia Display Connection Board/Process Module, No relays

AWI234 Integral 2/3/4 Wire, Housing/Facia Display Connection Board/Process Module, 2 relays

AWFI234 Integral 2/3/4 Wire, Housing/Facia Display Connection Board/Process Module, 2 relays for flow

HOUSING

S Standard Plastic Moulded Housing

POWER SUPPLY

B 24 VDC Standard

C 48VDC for 234 only

U Universal DC or AC power supply (12-30 VDC or 90-265 VAC input) for 234 units only

TRANSDUCER FREQUENCY

50 50kHz for applications 0-5m, available 2" only

40 40kHz for applications 0-7m, available 2" only

30 30kHz for applications up to 11m for 2" and 15m for 3" (4" cone is recommended for 3" units)

20 20kHz for applications up to 20m, available in 3" only (4" cone is recommended)

15 15kHz for applications up to 30m, available in 3" only (10" cone is recommended)

10 10kHz for applications up to 40m, available in 3.5" only (10" cone is recommended)

09 09Hz for high power extended range applications up to 170m (10" cone is recommended)

05 05kHz for applications up to 60m maximum, available in 3.5" only (10" cone is recommended)

04 04kHz for high power extended range applications up to 170m (10" cone is recommended)

PROCESS TEMPERATURE - Facing material selection

S Standard Temperature Dry atmosphere only, (polyolfin face) for 4, 5, 9 10 and 15kHz only

T Standard Temperature Wet or dry atmosphere (teflon face)

Y High Temperature (Wet or dry atmosphere, 150C, Titanium face) 10kHz only

TRANSDUCER HOUSING MATERIAL

4 Polypropylene, Standard 30, 20, 15, 5kHz (Large Housing)

6 Tefzel for 2" (standard). For 3" Teflon please contact us

THREAD STANDARDS (cone mounting thread does not need to be specified)

X Not Required (see flange & cone selection)

TB BSP (Must be used for thread sizes 30 or 50. For back cap mounting of flange.)

TN NPT

THREAD SIZES

X Not Required

20 2" thread for 50,40,30 kHz only

30 3" thread for 30,20,15 kHz only (For back cap mounting of flange, use TB option)

50 3.5" thread on the back cap for 5 and 10 kHz only (For back cap mounting of flange, use TB option)

ADDITIONAL COMMUNICATIONS

S Switch only. 5 relays for 2/3/4 only

X 4-20mA analogue output module, includes Modbus comms

H HART 2 wire only

I HART isolated 4 wire, 2/3/4 only

W Modbus comms only (not available for 2 wire)

P Profibus DP

A Profibus PA

F Foundation Fieldbus

E Ethernet

D DeviceNet

Z Special request

APPROVAL STANDARD

X Not Required

A0 ATEX 0 only for AWI2

A22 ATEX Dust (Areas II ID T85C IP67)

POSITION/CRANEMASTER SOFTWARE OPTIONS

PS Position Slave

CM Crane Master

X Not required

AWI2 S B 50 S 4 X X X X X

FLANGE SELECTION

FLANGE

F Flange Selection

DIMENSION STANDARD

- A ANSI
- D Din
- J JIS
- Z Special Request

FLANGE SIZES

- 2N 2" NPT flange
- 2B 2" BSP flange
- 3 3" flange
- 4 4" acoustically isolated flange
- 6 6" acoustically isolated flange
- 8 8" acoustically isolated flange
- 10 10" acoustically isolated flange
- Z Special Request

FLANGE MOUNTING POSITION

- A Cone Mounted
- B Transducer Body Mounted
- C Angle Flange

FLANGE MATERIAL

- 4 Polypropylene
- 6 Teflon
- Z Special Request

F A 4 A - 4

LOCKING RING

LR

- Not Required
- 4 For 4" and 6" flanges
- 8 For 8" cones for 15KHz
- 10 For 10" flanges/cones

Material

- 4 Polypropylene

LR 4 - 4

CONE SELECTION

CONE

C Focalizer Cone

CONE SIZE

- 02N Adaptor for 2" NPT Sensor to fit into 4" cone (included)
- 02B Adaptor for 2" BSP sensor to fit into 4" cone (included)
- 03 3" cone for 30,20 and 15kHz transducers with TB30 or TN30 threads
- 04 4" cone, 30 and 20kHz 3" transducer
- 08-15 8" cone, 15kHz
- 08-10 8" cone, 10kHz
- 10-15 10" cone, 15kHz
- 10-09 10" cone, 9kHz
- 10-10 10" cone, 10kHz
- 10-04 10" cone, 4kHz
- 10-05 10" cone, 5kHz

CONE MATERIAL

- 4 Polypropylene
- 6 Teflon
- 7 Carbon Fibre. Must be used with Carbon Fibre flange
- 7A Carbon Fibre - comes attached to Carbon Fibre ANSI flange
- 7D Carbon Fibre - comes attached to Carbon Fibre DIN flange
- 7J Carbon Fibre - comes attached to Carbon Fibre JIS flange
- 8 Polyurethane*
- Z Special Request

C 04 - 4

* Polyurethane can be compressed to fit into the next smaller nozzle mounting size, e.g.. 8" polyurethane cone will compress into a 6" nozzle and so is 10" polyurethane in to 8" nozzle. Please confirm the maximum nozzle height allowed.

Specifications

Frequency

- 5kHz, 10kHz, 15kHz, 20kHz, 30kHz, 40kHz, 50kHz (4/9 are long range versions of 5/10)

Operating Voltage

- 12 - 30Vdc (residual ripple no greater than 100mV)
- 90 - 265Vac 50/60Hz
- 48Vdc, 48Vac-90Vac 50/60Hz

Power Consumption

- <3W @ 24Vdc
- <10VA @ 240Vac
- <4W @ 48Vdc, <7VA @ 48Vac – 90Vac.

Analog Output

- 4 -20mA (750 ohms @ 24Vdc User supply, 250 ohms internally driven)

Communications

- Goshawk, HART, Modbus, Profibus DP, DeviceNet, Foundation Fieldbus and Profibus PA
- Multidrop mode can address 1 -250 units over 4 wires

Relay Output: (2) Integral (5) Remote

- Form 'C' (SPDT) contacts, rated 0.5A at 240Vac non-inductive.
- All relays have independently adjustable dead bands.
- Remote failsafe test facility for one relay.

Blanking Distance

- 50kHz = 0.25 m (10")
- 40kHz = 0.30 m (12")
- 30kHz = 0.35 m (14")
- 20kHz = 0.45 m (17")
- 15kHz = 0.60 m (24")
- 10/9kHz = 1.0 m (39")
- 5/4kHz = 1.5 m (59")

Maximum Range

- 5 m (16ft) 50kHz liquids
- 7 m (22ft) 40kHz liquids
- 10 m (33ft) 30kHz liquids, 5m (16ft) solids
- 20 m (65ft) 20kHz liquids/slurries, 10m (33ft) solids
- 30 m (98ft) 15kHz liquids/slurries, 20m (65ft) solids
- 50 m (165ft) 10kHz liquids/slurries/powders/solids
- 60 m (196ft) 5kHz liquids/slurries/powders/solids
- 180 m (588ft) 4/9 kHz for extended range

Resolution

- 1 mm (0.04") 50, 40, 30,20, 15, 10, 5kHz
- 4 mm (0.2") 9, 4kHz

Electronic Accuracy

- +/- 0.25% of maximum range

Operating Temperature

- Integral System -40°C (-40°F) to 80°C (176°F)
- Remote electronics -40°C (-40°F) to 80°C (176°F)
- Remote transducer -40°C (-40°F) to 80°C (176°F)
- -40°C (-40°F) to 175°C (Hi-Temp. 10kHz version)

Transducer/Amplifier Separation

- up to 1000m using specified extension cable

Cable

- 4 conductor shielded twisted pair instrument cable. Conductor size dependent on cable length. BELDEN 3084A, DEKORON or equivalent. Max: BELDEN 3084A = 500m (1640 ft) Max: DEKORON IED183AA002 = 350m (980 ft)

IMPORTANT
"USE SPECIFIED
CABLE ONLY"

Maximum Operating Pressure

- +/- 7.5 PSI (+/- 0.5 Bar)

Beam Angle

- 7.5° without focaliser 50kHz/40kHz/30kHz
- 4° with focaliser 50kHz/40kHz
- 6° with focaliser 30kHz/20kHz/15kHz/10kHz/5kHz
- 10° with focaliser 9kHz/4kHz

Display

- 2 line x 8 digit alphanumeric LCD

Memory

- Non-Volatile (No backup battery required)
- >10 years data retention

Enclosure Sealing

- Integral System IP67
- Remote Electronics IP65 (Nema 4x)
- Remote Transducer IP68

Cable Entries

- Integral: 3 x M16 Glands
- Remote: 3 x 20mm, 1 x 16mm knock outs.

Mounting

- ANSI, JIS or DIN Flange
- 4 in/100mm to 10 in/250mm
- 2in BSP Thread / NPT Thread

Typical Weight

Sultan AW System with appropriate flange and cone

| Frequency (in kHz) | kg | lb |
|--|----|------|
| 4/5 4 or 5kHz Transducer | 13 | 28.6 |
| 9/10 9 or 10kHz Transducer | 10 | 22.0 |
| 15 15kHz Transducer | 8 | 17.6 |
| 20/30 20 or 30kHz (3") Transducer | 3 | 6.6 |
| 30/40/50 30 (2"), 40 or 50kHz Transducer | 1 | 2.2 |

| Configuration | kg | lb |
|----------------------------------|----|------|
| R6 Remote system with 6m cable | 1 | 2.2 |
| R15 Remote system with 15m cable | 3 | 6.6 |
| R30 Remote system with 30m cable | 6 | 13.2 |
| R50 Remote system with 50m cable | 10 | 22.0 |

Additional product warranty and application guarantees upon request.

Technical data subject to change without notice.

Contact

Hawk Measurement Systems (Head Office)

15-17 Maurice Court
Nunawading VIC 3131
Australia
Phone: +61 3 9873 4750
Fax: +61 3 9873 4538
info@hawk.com.au

Hawk Measurement

7 River Street
Middleton, MA 01949
USA
Phone: +1 888 HAWKLEVEL (1-888-429-5538)
Phone: +1 978 304 3000
Fax: +1 978 304 1462
info@hawkmeasure.com

Represented by:

